

# Katalogový list

platný od: 1/1/22

**+GF+**



**TITAN**  
METALPLAST

## Elektrotvarovka sedlová, navrtávací T-kus odbočkový KIT, otočný vývod 360°

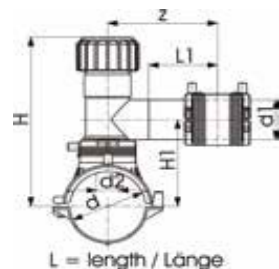
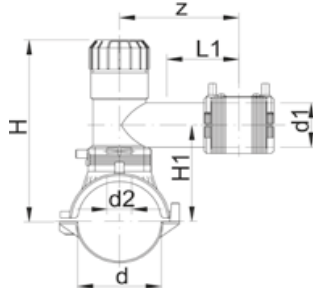

- PE 100 SDR 11 (ISO S5)
- 10 bar plyn / 16 bar voda
- S integrovaným vrtákem pro navrtání potrubí pod tlakem
- Rozměr inbusového klíče pro navrtávání - 17 mm
- Včetně spodního třmenu
- 4 mm svařovací konektory
- Kontrolní výronek s ochranou proti vytečení taveniny
- Prodloužený vývod
- Šroubovací víčko s O-kroužkem
- Dodáváno jako sada včetně elektrospojky nebo elektroredukce
- d 315-400 mm; nevhodné pro trubky se silou stěny větší než SDR 17
- \* Dodáváno bez spodního třmenu, montáž pomocí přípravku TOPLOAD 799-350-477

d	d1	obj. číslo	Hmotn.	d2	H	H1	L	L1	z	SDR trubky
(mm)	(mm)		(kg)	(mm)	(mm)	(mm)	(mm)	(mm)	(mm)	
63	20	193 132 402	0.754	32	186	108	165	76	130	9 - 11
63	25	193 132 403	0.761	32	186	108	165	76	130	9 - 11
63	32	193 132 404	0.773	32	186	108	165	76	130	9 - 11
63	40	193 132 405	0.798	32	186	108	165	76	130	9 - 11
63	50	193 132 436	1.619	32	234	112	165	100	160	9 - 11
63	63	193 132 437	1.623	32	234	112	165	100	160	9 - 11
75	20	193 132 442	0.879	32	191	113	165	76	130	9 - 11
75	25	193 132 443	0.900	32	191	113	165	76	130	9 - 11
75	32	193 132 444	0.917	32	191	113	165	76	130	9 - 11
75	40	193 132 445	0.958	32	240	118	165	76	160	9 - 11
75	50	193 132 446	1.748	32	240	118	165	100	160	9 - 11
75	63	193 132 447	1.753	32	240	118	165	100	160	9 - 11
90	20	193 132 452	0.856	32	199	121	165	76	130	9 - 17.6
90	25	193 132 453	0.858	32	199	121	165	76	130	9 - 17.6
90	32	193 132 454	0.857	32	199	121	165	76	130	9 - 17.6
90	40	193 132 455	0.780	32	199	126	165	76	130	9 - 17.6
90	50	193 132 456	1.711	32	248	126	165	100	160	9 - 17.6
90	63	193 132 457	1.707	32	248	126	165	100	160	9 - 17.6
110	20	193 132 462	0.907	32	209	131	165	76	130	9 - 17.6
110	25	193 132 463	0.905	32	209	131	165	76	130	9 - 17.6
110	32	193 132 464	0.875	32	209	131	165	76	130	9 - 17.6
110	40	193 132 465	0.961	32	209	136	165	76	130	9 - 17.6
110	50	193 132 466	1.133	35	258	136	165	100	160	9 - 17.6
110	63	193 132 467	1.330	35	258	136	165	100	160	9 - 17.6
125	20	193 132 472	0.938	32	216	138	165	76	130	9 - 17.6
125	25	193 132 473	0.943	32	216	138	165	76	130	9 - 17.6
125	32	193 132 474	0.955	32	216	138	165	76	130	9 - 17.6
125	40	193 132 475	0.964	32	216	143	165	76	130	9 - 17.6
125	50	193 132 476	1.374	35	256	143	165	100	160	9 - 17.6
125	63	193 132 477	1.161	35	256	143	165	100	160	9 - 17.6
140	20	193 132 482	0.941	32	234	146	165	76	130	9 - 17.6
140	25	193 132 483	0.944	32	234	146	165	76	130	9 - 17.6

# Katalogový list

platný od: 1/1/22

**+GF+**

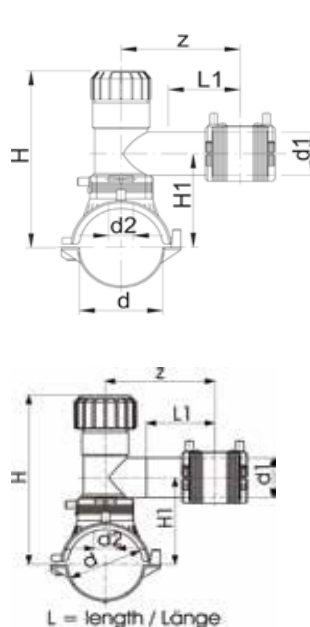

	140	32	<b>193 132 484</b>	0.972	32	234	146	165	76	130	9 - 17.6
	140	40	<b>193 132 485</b>	1.020	32	234	146	165	76	130	9 - 17.6
	140	50	<b>193 132 486</b>	1.835	35	283	151	165	100	160	9 - 17.6
	140	63	<b>193 132 487</b>	1.833	35	283	151	165	100	160	9 - 17.6
	160	20	<b>193 132 492</b>	0.910	32	234	156	165	76	130	9 - 17.6
	160	25	<b>193 132 493</b>	0.933	32	234	156	165	76	130	9 - 17.6
	160	32	<b>193 132 494</b>	0.954	32	234	156	165	76	130	9 - 17.6
	160	40	<b>193 132 495</b>	0.965	32	234	161	165	76	130	9 - 17.6
	160	50	<b>193 132 496</b>	1.375	35	283	161	165	100	160	9 - 17.6
	160	63	<b>193 132 497</b>	1.378	35	283	161	165	100	160	9 - 17.6
	180	20	<b>193 132 502</b>	1.020	32	244	166	165	71	130	9 - 26
	180	25	<b>193 132 503</b>	1.057	32	244	166	165	71	130	9 - 26
	180	32	<b>193 132 504</b>	1.045	32	244	166	165	76	130	9 - 26
	180	40	<b>193 132 505</b>	1.122	32	244	171	165	76	130	9 - 26
	180	50	<b>193 132 506</b>	1.938	35	293	171	165	100	160	9 - 26
	180	63	<b>193 132 507</b>	1.918	35	293	171	165	100	160	9 - 26
	200	20	<b>193 132 512</b>	1.065	32	254	176	165	76	130	9 - 26
	200	25	<b>193 132 513</b>	1.065	32	254	176	165	71	130	9 - 26
	200	32	<b>193 132 514</b>	1.095	32	254	176	165	76	130	9 - 26
	200	40	<b>193 132 515</b>	1.131	32	254	181	165	76	130	9 - 26
	200	50	<b>193 132 516</b>	1.957	35	303	181	165	100	160	9 - 26
	200	63	<b>193 132 517</b>	1.900	35	303	181	165	100	160	9 - 26
	225	20	<b>193 132 522</b>	1.460	32	266	188	165	71	130	11 - 26
	225	25	<b>193 132 523</b>	0.991	32	266	188	165	71	130	11 - 26
	225	32	<b>193 132 524</b>	1.095	32	266	188	165	76	130	11 - 26
	225	40	<b>193 132 525</b>	1.134	32	266	193	165	76	130	11 - 26
	225	50	<b>193 132 526</b>	1.921	35	315	193	165	100	160	11 - 26
	225	63	<b>193 132 527</b>	1.951	35	315	193	165	100	160	11 - 26
	250	20	<b>193 132 532</b>	1.079	32	279	201	165	76	130	11 - 26
	250	25	<b>193 132 533</b>	1.095	32	279	201	165	76	130	11 - 26
	250	32	<b>193 132 534</b>	1.092	32	279	201	165	76	130	11 - 26
	250	40	<b>193 132 535</b>	1.113	32	279	206	165	76	160	11 - 26
	250	50	<b>193 132 536</b>	1.971	35	328	206	165	100	160	11 - 26
	250	63	<b>193 132 537</b>	1.923	35	328	206	165	100	160	11 - 26
*	280	32	<b>193 132 544</b>	1.455	35	343	206	165	100	160	11 - 26
*	280	40	<b>193 132 545</b>	1.500	35	343	206	165	100	160	11 - 26
*	280	50	<b>193 132 546</b>	1.500	35	343	206	165	100	160	11 - 26
*	280	63	<b>193 132 547</b>	1.510	35	343	206	165	100	160	11 - 26
*	315 - 355	32	<b>193 132 554</b>	1.648	35	381	206	165	100	160	17 - 33
*	315 - 355	40	<b>193 132 555</b>	1.015	35	381	206	165	100	160	17 - 33
*	315 - 355	50	<b>193 132 556</b>	1.440	35	381	206	165	100	160	17 - 33
*	315 - 355	63	<b>193 132 557</b>	1.602	35	381	206	165	100	160	17 - 33

Technické údaje jsou nezávazné. Konstrukční a rozměrové změny vyhrazeny.  
Platí naše všeobecné obchodní podmínky.

**TITAN - METALPLAST s.r.o.** / Volgogradská 106 / 460 10 Liberec - Karlínky  
telefon: (+420) 483 359 061 / e-mail: obchod@titan-metalplast.cz / [www.titan-metalplast.cz](http://www.titan-metalplast.cz)